

# British Motoring Club—New Orleans Morris Gazette

September 2008

Published Monthly

## President's Message

*BMCNO is affiliated  
with*

**North American MGB  
Register (NAMGBR)  
and  
Vintage Triumph Regis-  
ter (VTR)**

If you are member of these or  
any other national club or  
register, please let us know.

We strongly encourage all  
members to join the  
registry for their  
marque!

### Inside this issue:

<i>Calendar</i>	2
<i>Officers &amp; Membership Info</i>	3
<i>Minutes</i>	4
<i>Guest Speaker &amp; Article reprint</i>	5
<i>Annual Richard Wolf UnCar Show</i>	6-7
<i>Dorset Conversions</i>	8
<i>Board of Directors Summer BBQ</i>	9
<i>MG Car produc- tion</i>	10
<i>Classified</i>	11

British Motoring Club – New Orleans is celebrating its 30th anniversary this year. Originally founded in 1978 as the Louisiana Centre MG Car Club, the name was changed so that all British marque owners were welcome.

To celebrate this occasion, your Board has several interesting projects in the works. First and foremost, we are planning an anniversary party to be held in conjunction with our annual Christmas party on December 7th. We have booked the Bocce Italia Club at 2340 Severn Ave. in Metairie, LA. This will be a catered affair with displays, a slideshow of past events, door prizes and a commemorative dash plaque. Mark your calendars; this is one party you will not want to miss!

Ronnie Palmisano has been gathering old newsletters and he will soon be scanning them for our website. Our goal is to have every Morris Gazette ever published on the web for you. It's a daunting task, so be patient.

The annual Shaun Hayden Memorial Funkana will again be held at Arrow Aviation in Broussard, LA. On Saturday, September 6<sup>th</sup>, Dave will have a poker run at 4:00 p.m. The Funkana starts at 10:30 a.m. on Sunday, September 7<sup>th</sup>. At present, we have not set up any formal convoys from New Orleans, Mandeville or Baton Rouge. If you are planning on going, please e-mail Dave at [dandmhayden@cox.net](mailto:dandmhayden@cox.net) and me at [president@bmcno.org](mailto:president@bmcno.org) and let me know if you are going on Saturday or Sunday.

Menda Hayden is still collecting recipes for the BMCNO cookbook. She was hoping to have 100 recipes and photos from members by the end of July. She has only received 20 thus far. We would really like to get this done in time for Christmas so please send in your favorite dish now. Send them to Menda at [dandmhayden@cox.net](mailto:dandmhayden@cox.net).

Keith

## September 2008

Sun	Mon	Tue	Wed	Thu	Fri	Sat
	1 <i>Labor Day</i>	2	3	4	5	6 Acadiana Cruise & Funkana
7 Acadiana Cruise & Funkana	8	9	10	11	12	13
14	15	16 B.O.D. Mtg. 7:00pm	17	18	19	20
21	22	23	24	25	26 Final Friday 5-10 p.m. Downtown Cov- ington	27 Vidalia Show, Brits by the River convoy  Lafayette Area Cruise
28 Vidalia Show, Brits by the River show	29	30 Membership Mtg. 7:00pm @ The Ital- ian Pie				

### Saturday & Sunday, September 6 & 7 - Acadiana Poker Rallye & Funkana

**Saturday 4:00 p.m.** - Poker rallye. Starts at the host hotel in New Iberia and ends with dinner.

**Sunday 10:30 a.m.** - Funkana at Arrow Aviation, 1318 Smede Hwy., Broussard, La.

The host hotel is Days Inn, 611 Queen City Drive (Hwy. 90 @ Hwy. 14), New Iberia, La. 337-560-9500

Ask for the BMCNO Funkana special room rate. Reservations must be made by August 31st for the rate.

Please e-mail or call to let us know you will be joining us. This will help us with timing of events and food reservations.

Contact Dave or Menda at [dandmhayden@cox.net](mailto:dandmhayden@cox.net) or 337-937-4929

**Tuesday, September 16 - 7:00 p.m. Board Meeting** - Harold O'Reilly @ Karen Murray's. 1900 Colony, Metairie.

**Friday, September 26 - 5:00 p.m.-10 p.m. Final Friday** Covington, LA - A street party featuring all types of antique cars, including British cars. Four blocks of Columbia St. are closed for a car display. Most restaurants are open and live music at both ends of the street. Call Cliff Hughes (985) 845-8709

**Friday, 27 - Brits by the River** - Southshore leaves Kenner Visitor's Center (I-10 @ Loyola) at 8:00 a.m., Northshore leaves from the Texaco station (I-12 @ Rt. 21) at 8:00 a.m. Both convoys meet up at Rick & Mary Lynne Huber's home at 746 Saint Landry St. in Baton Rouge at 9:30 a.m. (225) 926-6946. We'll have lunch at the Carriage House in Natchez.

**Saturday, September 27 - Lafayette Area Cruise** - For more information, contact Dave Hayden at [dandmhayden@cox.net](mailto:dandmhayden@cox.net)

**Saturday, September 28 - Brits by the River Show- Vidalia, LA.** (See page 9 for more information)

**Tuesday, September 30 - 7:00 p.m. GENERAL MEETING** - Italian Pie, 5650 Jefferson Hwy.

***NOMINATION OF OFFICERS!***

## Club Officers – 2008

### Board of Directors

President:	Keith Vezina	504-443-5056	president@bmcno.org
Vice President	Karen Murray	504-236-7509	karenmurray@cox.net
Treasurer	Allen Bradley	504-888-6887	abmgbtr6@bellsouth.net
Secretary	Cathy Greensfelder	504-392-9261	secretary@bmcno.org
Editor	Ronnie Palmisano	504-454-3461	ronniep@cox.net

### Members at Large

Wally Friloux	985-845-8216	twofrilouxs@bellsouth.net
Robert Rougelot	985-809-7007	rcrougelot@charter.net
Robert Phillips	504-896-2304	rp826union@aol.com
Harold O'Reilly	504-289-6982	haroldor@bellsouth.net

### Coordinators

North American MGA Register	Frazer Rice	504-314-1157	ricefrazer@yahoo.com
North American MGB Register	Henry Bourgeois	985-893-7610	bayouboo@hughes.net
Vintage Triumph Register	Harold O'Reilly	504-289-6982	haroldor@bellsouth.net
Webmaster	Keith Vezina	504-443-5056	webmaster@bmcno.org
Baton Rouge Area Coordinator	Rick Huber	225-926-6946	mlandrick@gmail.com
Lafayette Area Coordinator	Dave Hayden	337-937-4929	dandmhayden@cox.net
Mandeville Area Coordinator	Patrick Park	985-710-2941	ppark5960@yahoo.com

**Membership Info-** Club membership is open to anyone who owns or has owned,, drives or is interested in British motor vehicles.

Annual Dues: \$24 per year (July 1st to June 30th).

Dues are prorated for the first year at \$2.00 per month.

Lifetime Membership: \$240

Please pay your dues promptly to avoid missing any issues of the *Morris Gazette*. Mail renewal checks payable to "BMC-NO" to: Treasurer, PO Box 73213, Metairie, LA 70033



**Club Regalia** - Contact the Club Treasurer Allen Bradley for information.

License Plate Frame \$5.00 (2 for \$9.00)      Windscreen Transfer \$ 1.00    T-shirt \$10.00

**Newsletter Submissions** - Electronic article submissions are greatly preferred. Email to ronniep@cox.net, bring to meeting, or mail to P.O. Box 73213, Metairie, LA 70033



## LUBRIPORT LABORATORIES, INC.

*PROUDLY SERVICING THE PETROLEUM & MARINE INDUSTRIES*

PETROLEUM LABORATORY SERVICE – USED LUBE OIL ANALYSIS  
PREVENTIVE MAINTENANCE ANALYSIS – DIESEL & RESIDUAL FUELS TESTING  
NEW LUBRICANT QUALITY ASSURANCE – EMISSION SPECTROMETER ANALYSIS

(504) 464-1734 – 1650 AIRLINE DRIVE – KENNER, LA 70062  
ANNE & FLOYD FRILOUX, OWNERS

## July Meeting Minutes

Thirty members and guests attended the July meeting. Guests included George Torlage of Delgado and Scott Broome. George teaches the Paint & Body classes at Delgado. Scott Broome has a 74 TR6 and a 95 Jaguar XJ6. Long time member Jim Jones was back after a long absence. Glad to see you again, Jim.

**Past Events:** Harold O'Reilly was the only member to attend the breakfast at Elizabeth's in Bywater. The food and service was great but no company. The Delgado tech session on wheel alignment was cancelled at the last minute when the machine broke. Jim Jones said he usually sets the front end of an MGB with 2 rods and a connecting grommet. (All you can set on a 'B is toe in.) The Board of Directors had their annual BBQ and "Fold, Staple and Mutilate" party to assemble the club directories and membership cards. You can participate next year by simply running for any club office!!

**Future Events:** Plans for the UnCar Show were discussed. The Exxon Valdez award for biggest oil leak will be renamed in honor of the recent barge accident that closed the MS River for a week. Cliff Hughes suggested an "Oldest Brake Tag" award - his expired in the late eighties. Discussion ensued over whether our cars were required by law to have safety inspections. Most people believed that a car over 40 years old with antique plates was exempt.

This year is the club's 30<sup>th</sup> anniversary. We are planning a com-

bined 30<sup>th</sup> Anniversary and Christmas party."

**Club Business:** Karen Murray reported that scholarship applications will be delivered to Delgado in August. The club will be awarding four \$500 scholarships this year. Allen Bradley gave the treasurer's report on the club and the show. A written report is available upon request.

**Member Projects:** Rick Huber brought a copy of an article published in the Baton Rouge paper on June 23<sup>rd</sup> on guys and their workshops. Baton Rouge resident Bob Gullick had an Austin Healey, a race prep MG-TF and an MGA (Frazer Rice's old, flooded MGA). There are several British cars listed for sale in the BR area. Contact Rick for more information.

Cliff Hughes' Healey was used in a photo shoot for Macy's. George Torlage called a couple of weeks ago saying Macy's was looking for a "sexy" car for a publicity photo shoot. Cliff suggested his 1958 red and white Austin Healey. George asked how much Cliff wanted - Cliff said no one ever paid before!! Cliff brought the car over at 2pm the next day for them to take pictures of the car with a super model. Unfortunately for Cliff, it was a male model!! They spent 20 minutes taking pictures of some skinny guy pretending to get in the car and that was it - done! Nice work if you can get it!

Bill Harris reported on the NAMGBR national show in Valley Forge, PA this year. 380 cars were entered. His blue car

placed 5<sup>th</sup> last year at Gatlinburg. He talked to all the judges afterwards to find out where he lost points and spent the past year fixing everything he could. This year the car placed 2<sup>nd</sup>. It was beaten by a car with fourteen original miles on it. There's no way for a car that is actually driven to compete with something that's never been on the road. (What a shame! These cars were not built to sit in a garage.) The 2009 NAMGBR national will be in Breckenridge, CO.

Frazer Rice went to the NAMGAR national in the Pittsburg area. 153 MGAs were entered. Next year's MGA national is in Hot Springs, AR, which is not that bad a drive.

Both Bill and Frazer highly recommend you try a national show. They are Wednesday through Sunday events with multiple activities each day - Funkanas, cruises, rallies, dinners, tech sessions - and hundreds of cars.

The first ticket drawn for the 50/50 drawing for \$17 was unclaimed. A second ticket was drawn and Robert Rougelot won. Antique dash plaques were won by Harold O'Reilly, Karen Murray, Ronnie Palmisano, Don Marpe and Allen Bradley.

The meeting was adjourned to the Creole Creamery on Prytania Street in Uptown New Orleans.

## Guest Speaker

Guest Speaker George Torlage, paint and body work instructor at Delgado, spoke to the group at the meeting on July 29. First he congratulated us on putting on a fine show this year. George figured it would be a good time to show off the new body shop so he volunteered to conduct a tour. He expected maybe four people would be interested. Wrong!! There were around forty! He showed off the place and everyone really enjoyed it. Since the show, the second spray booth has been installed which will be really nice in the class. Someone was always waiting for the booth last year.

Classes start in late August. The paint and body class is 6

pm to 9 pm and George is planning for a Monday – Wednesday section since he knows we meet on Tuesdays. He wants to limit that section to hobbyists like us. We have a different focus than his regular Delgado students. (Although the students sort of adopted Richard Baker last semester. Or maybe Richard adopted them - they got along great.)

If you are interested in taking the class, call Delgado. With tuition and materials, you can paint your car for around \$500. Remember, this will be primarily a paint class - no “basket cases”, only cars needing minimal body work. There won't be time or facilities for real problem cars.

Next year he really would like

to divide up the class and do primarily body work in the fall semester, with just enough spray work to do the priming, then really concentrate on painting in the spring semester. With doing it all together, by the time students finished the body work and were ready to paint, there wasn't enough time for them to really perfect their spraying technique. George ended up doing some of the painting himself.

George was asked if he could arrange for a paint company representative to come speak to our group in the future. Several members expressed interest in learning about different types of paint. George also will try to get us the name of a wax and buffing system rep to come talk to us about compounding.

## Article reprint from the June 1 1990 Morris Gazette

This article was submitted by Bob Lee. He was a member from long ago. It was run in the November 1981 issue of the Morris Gazette and is a reprint from the October, 1981 issue of "The Delta Sierran".

### Club Run By A Clique!

Any smoothly-functioning club gives new members the impression that the club is run by clique. The following piece, penned by an anonymous writer presents the situation accurately:

Rumor has it that the club is run by a 'clique'. Careful inves-

tigation would show that this is true. Furthermore, you will find that the clique is composed of faithful members who are present at all meetings, who do all the work, who give willingly of their time, energies and efforts, and who sincerely believe that the more they put into the club, the more they will get out of it. There is no question that the enthusiasm, responsibility, and efforts of those members are of inestimable value to the club. And it is suggested, therefore, that you join this clique. It is not a difficult matter to do so in fact, it **is** very easy.

Begin by attending your club regularly; take a lively interest in its activities; accept responsibilities in the work; never refuse a place of service. Show a continual interest in all affairs pertaining to your club. Before you realize it, you will become a member of the clique and you will be surprised to know how anxious they are to have you. Don't criticize the clique. Join it!

(Sent in by Karen Murray for reprint)

# Annual Richard Wolf UnCar Show

This year the annual Richard Wolf UnCar Show was held on Sunday, August 10, at the Columbia St. Tap Room & Grill, 434 N. Columbia St., Covington. The event was from 4:00-7:00 p.m.

Prizes were awarded in an assortment of categories from oil leaks to bad paint. The club purchased dinner for the driver of each car entry. This year twelve cars entered this exciting event. There was something for everyone. We enjoyed car judging, great food, conversation and especially the A/C in the restaurant.

And the winners are:



Tom Daughdrill "Largest Dent & Worst Paint"



Allen Bradley "Largest Oil Leak"



Robert Rougelot "Most Bugs & cracked windshield"



Ronnie Palmisano "Worst Interior"



Patrick Park "Goodwill Award"



Cort Musgrave "Dirtiest Engine"



Cliff Hughes "Boot Award-most likely to walk home"



1975 Triumph



Roger Nagy "Worst Wheels"



Robert and Allen having a good time!



Columbia St. Tap Room & Grill



Wally, Margaret and Jim discussing world events.

Annual Richard Wolf UnCar Show pictures continued from page 6



## DORSET CONVERSIONS By Jim Jones

**OPERATING PEDALS:** The Dorset's original operating pedals (accelerator, brake, & clutch) have been retained. No swing pedal assembly here! The accelerator pedal operates a Weber down draught two barrel carburetor via a custom rotary linkage system using Austin Healey parts.

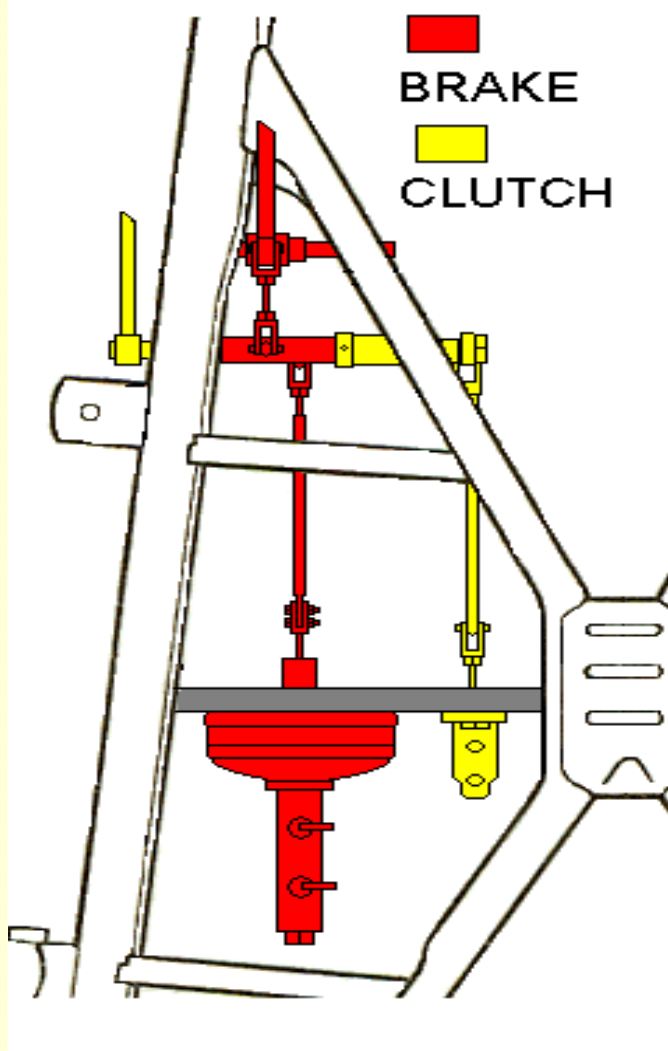

It is a nice setup, but it does cause the accelerator pedal to move some when the engine rocks side to side. The linkage setup may be changed to cable operation.

The brake pedal now operates a late model MGB dual circuit master cylinder (Vic. P/N 7-519) with vacuum booster (Vic. P/N 7-596-Z).

An Austin Healey remote dual chambered reservoir (Vic. P/N 7-795) mounted to the left hand

side of the engine bay upper firewall supplies the rear brake master cylinder fitting (large section) and clutch master cylinder (small section) with fluid.

A firewall mounted single chambered Austin Healey reservoir (Vic. P/N 7-297) supplies the

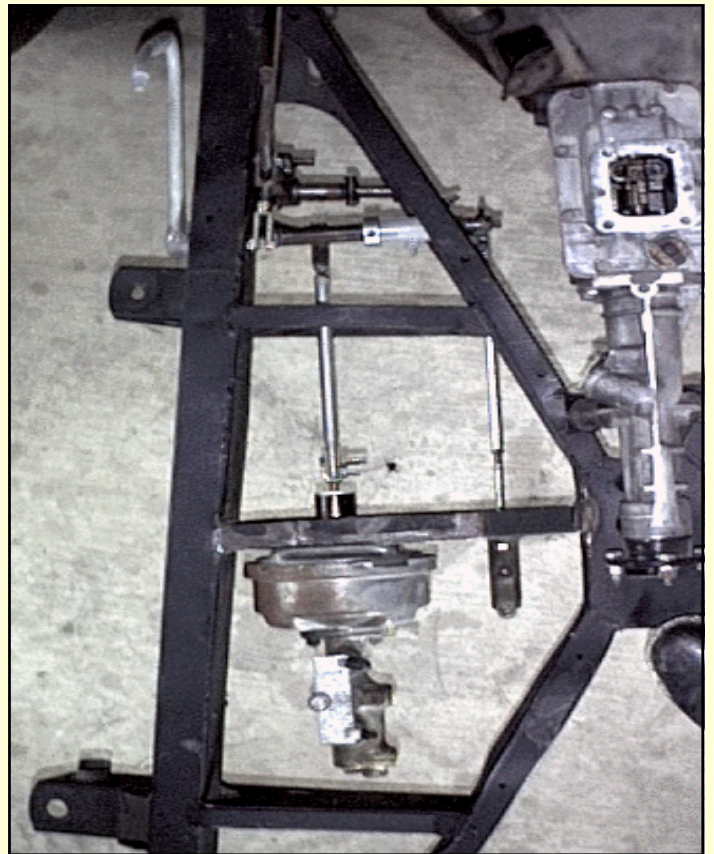

front disc brake master cylinder with fluid.

The clutch pedal operates a 1959 to 1968 Austin Healey clutch master cylinder unit.

The grey colored cross member was added to the frame in order to be able to mount the brake & clutch hydraulic assemblies.

All this is out of sight and just one part of all the discrete upgrades installed on the Austin of England, Dorset. The Dorset is one of a 170 cars of this model that were manufactured by the Austin company in 1949-1950. Some records indicate that, in fact, no cars were made in 1950.



## Board of Directors Summer BBQ

On Sunday, July 20<sup>th</sup> we had our annual BMCNO Board Meeting & Family BBQ / Pool Party at the home of Karen Murray and Ronnie Palmisano.

At this meeting, club business was conducted in a more relaxed way than usual. For instance, in the swimming pool.

Club President Keith Vezina brought his usual items to this BBQ. Included were country style pork ribs, smoked Cajun sausage, BBQ shrimp, and other. Karen prepared her usual feast. Karen's usual feast is something like the buffet at the Paris Casino in Las Vegas, but on a smaller scale.

Board member elections are soon. If there is only one reason to become a board member, then this is it.



Club President Keith Vezina



Lunch



Karen, Keith, and Mark



Amelia and Karen



Robert and his daughter Amelia

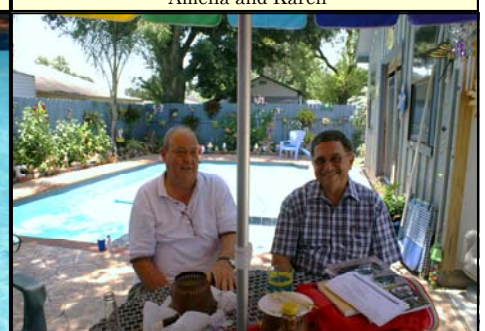

Harold and Wally

## English Motoring Club - Brits By The River / Vidalia LA

### SEPTEMBER 26 - 27, 2008 - Brits By The River / Vidalia LA

The 11th Annual Brits by the River British Car Show & Competition will be held on September 26th & 27th, 2008.

Go to <http://www.msemc.org/BBTR%20Flyer%202008.pdf> for information and registration form.

#### Overnight Accommodations

A block of rooms has been reserved at the Comfort Suites Riverfront Hotel, 100 Front Street, Vidalia, LA 71373. Call their toll-free number at (800) 260-2715 or go to [www.choicehotels.com](http://www.choicehotels.com). There is a special EMC rate of \$90 levee-view and \$100 river-view per night. When making reservations please be sure to tell the reservationist you are with the English Motoring Club.

#### Schedule of Events

I. Registration/Evening Social 5pm - 7pm, Friday  
River View RV Park Clubhouse

Light Hors d'oeuvres  
List of restaurants to be provided

II. Parade 9:30am-10am  
Comfort Inn to Show Site

III. Registration 10am – Noon, Saturday  
South end of Riverfront Park

IV. Show & Competition Noon to 2pm  
South end of Riverfront Park

V. Judging Noon to 1pm

VI. Awards Presentation 2pm, Show Site

For more info contact:

John Turbeville - (601) 940-5288 - [joturbe@comcast.net](mailto:joturbe@comcast.net)  
Gene Johnston - (601) 607-7021  
[jjohnston18@comcast.net](mailto:jjohnston18@comcast.net)

## Car production has restarted at the former MG Rover plant in Longbridge, Birmingham.

Shanghai Automotive (SAIC) said it had sold 70% of the orders for its new model, the MG TF LE500.

However, it has been suggested the production is not "full scale" as the engines and bodies are being shipped over from China for hand finishing.

An MG UK spokeswoman said Longbridge did have a "full-on" production line with 180 workers on site. Eleanor de la Haye, of MG UK, said: "We have 180 workers on site working, not necessarily on that line but on support services as well.

"We are hand building cars. We are producing them in the same way we would expect from any other manufacturing facility."

Former Jaguar chief executive Sir Nick Scheele said this could damage the brand for anyone wanting to buy a "British" car.

He said: "The brand must elicit trust and trustworthiness from potential customers."

The company has 55 dealers across the UK and believes the first cars will be with customers by next month.

MG Rover collapsed in 2005 with the loss of about 6,000 jobs. It was bought by Nanjing Automobile Corporation for £53m but they were taken over by SAIC.

### 'Looking forward'

SAIC said it hoped to produce 700 of its sports cars by the end of the year. The model will cost nearly £16,500.

Ms. de la Haye said: "We are delighted to have reached this important point and are looking forward to seeing the cars in showrooms shortly."

Birmingham City Council leader Mike Whitby said: "This is truly an historic day for our city and our region and it points towards a much brighter

future.

"Combined with Tata's recent collaboration with Jaguar and Land Rover this is bringing the re-birth of our automotive industry one step closer to reality."

Longbridge was opened in 1905 by motoring legend Herbert Austin.

As well as producing cars, it was used as a munitions factory during both world wars and began production of the iconic Mini in 1959.

It also produced the popular Metro and Rover 200 models before the Rover company was bought by BMW in 1994.

BMW subsequently sold the firm to the Phoenix Consortium, under whom it went into administration in 2005.

From BBC News [http://news.bbc.co.uk/1/hi/england/west\\_midlands/7536527.stm](http://news.bbc.co.uk/1/hi/england/west_midlands/7536527.stm)



Owners SAIC say 700 MG TFs will be produced by the end of the year.

# Classified

**1960 MGA 1600** 300 miles since bumper to bumper rebuild.. Also Classic Roadster DUKE. Replica of 1937 Jaguar SS-100. 2.3 liter all ford mechanicals. Too many cars and not enough space!! John Wells 985-345-1166

**1974 Triumph TR6** Project Car for sale. Has all parts to restore the vehicle. Retired. Must pick up outside of Baton Rouge, LA. Price negotiable. Asking \$1000. Call Bill at 225-567-3035 for details.

**1979 MGB** FOR SALE CHEAP . 81,619 Miles car runs and drives, very solid, no rust. La. Title Dave Hayden 337-937-4929

**97 Jaguar XK8** Coupe Blue with Cream Interior. 180,000 mile but Lubriport test says motor in great shape, new transmission. \$10,000 Don Marpe 504-394-6343

## Classified Submissions

Electronic article submissions are greatly preferred. Email to [ronniep@cox.net](mailto:ronniep@cox.net), bring to meeting, or mail to P.O. Box 73213, Metairie, LA 70033 . There is no charge. The add will run for three months.

**Shop Online at [www.VictoriaBritish.com](http://www.VictoriaBritish.com) or Request Your FREE Catalog Today!**

Choose From These Parts and Accessories Catalogs:

- Austin Healey
- MGA
- MGB & MGC
- AH Sprite & MG Midget
- Sunbeam Alpine & Tiger
- TR2 TR3 TR4 TR4A TR250
- TR6
- TR7 & TR8
- Spitfire & GT6

Order Toll Free 7 Days A Week  
**1-800-255-0088**

**SUNBEAM**



Shop Online ... Fast, Simple & Safe  
[www.VictoriaBritish.com](http://www.VictoriaBritish.com)

24 Hours a Day • Orders • Catalog Requests • Status • 7 Days a Week

# OUR SERVICE PUTS US A-PART FROM THE REST.

At Little British, we know who we are and where our business comes from. As a growing company founded in the late 90's, we take pride in giving you high quality customer service. We will have the parts you need, the convenience you want, and at a lower price than you thought you would pay.

By being an online based company, we are able to keep costs low and maintain a flawless ordering system that is quick and user friendly. We have the parts for most British marques and models as well as fun collectibles and other useful items for the British car enthusiast. Log on to [www.LBCarCo.com](http://www.LBCarCo.com) and see why we excel at what we do.



**Little British Car Company**  
**[www.LBCarCo.com](http://www.LBCarCo.com)**

Jeff Zorn • 29311 Aranel Farmington Hills, MI 48334  
Phone: 248-489-0022 • Toll-free: 800-637-9640  
Fax: 248-489-9665 • Email: [LBCarCo@LBCarCo.com](mailto:LBCarCo@LBCarCo.com)  
Major credit cards accepted

Authorized Distributor for



**Pertronix Electric Ignitions and Coils**

**Vintage Ads**

**Don Hoods**

**Mota-Lita Steering Wheels**

**Gunson Tools**

**Moss Motors**

**Halogen Bulbs for Most British and American Cars**

**Plus many others!**



# The Morris Gazette

POST OFFICE BOX 73213

METAIRIE LA 70033



Visit us on the Web

[www.bmcno.org](http://www.bmcno.org)

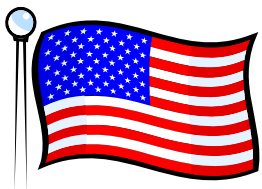

## September 2008

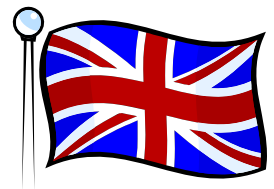

**August 26<sup>th</sup> GENERAL MEETING  
NOMINATION OF OFFICERS!**

**September 6<sup>th</sup> & 7<sup>th</sup> - Acadiana Cruise & Funkana**

**September 26<sup>th</sup> & 27<sup>th</sup> - Brits by the River, Vidalia**